

GCM

Gary - Chicago - Milwaukee ITS Priority Corridor

Corridor Transportation Information Center

System Definition Document Document #9931.06

**PROPRIETARY AND
CONFIDENTIAL**

Prepared by: De Leuw, Cather & Company
University of Illinois at Chicago
Electrical Engineering and
Computer Science Department

Issue Date: April 1, 1997

**GARY-CHICAGO-MILWAUKEE CORRIDOR
CORRIDOR TRANSPORTATION INFORMATION CENTER
SYSTEM DEFINITION DOCUMENT**

TABLE OF CONTENTS

1	INTRODUCTION	1-1
	1.1 PURPOSE	1-1
	1.1.1 Goals of this Document	1-1
	1.1.2 Intended Audience	1-1
	1.2 SCOPE.....	1-1
	1.3 DEFINITIONS, ACRONYMS, AND ABBREVIATIONS	1-2
	1.4 RELATED DOCUMENTS.....	1-2
2	SYSTEM OVERVIEW	2-1
3	GOALS AND OBJECTIVES	3-1
4	SYSTEM ARCHITECTURE	4-1
5	OPERATING AND DESIGN CONSTRAINTS	5-1
6	EXTERNAL SYSTEMS - INPUT	6-1
	6.1 ILLINOIS DATA SOURCES.....	6-2
	6.2 INDIANA DATA SOURCES.....	6-3
	6.3 WISCONSIN DATA SOURCES	6-4
7	EXTERNAL SYSTEMS - OUTPUT	7-1
	7.1 AREAWIDE DATA.....	7-1
	7.1.1 Internet Data Receivers.....	7-1
	7.1.2 Direct Communication Line Data Receivers	7-1
	7.1.3 Other Data Receivers.....	7-2
	7.1.4 Media Interface.....	7-2
	7.2 LOCAL DATA.....	7-2
8	LOCATION REFERENCING	8-1
9	USER INTERFACE	9-1
10	C-TIC HARDWARE AND OPERATING SYSTEM	10-1
11	DATA PROTOCOL	11-1

LIST OF FIGURES

Figure 1. High-Level System Architecture.....4-2
Figure 2. C-TIC Dataflow Description4-3
Figure 3. C-TIC High-Level Dataflows4-4
Figure 4. Current *ADVANCE* (C-TIC) Hardware Interconnections 10-1

LIST OF TABLES

Table 1 - C-TIC Features vs. Release6-1
Table 2 - C-TIC Input Data Types..... 11-1

**GARY-CHICAGO-MILWAUKEE CORRIDOR
CORRIDOR TRANSPORTATION INFORMATION CENTER
SYSTEM DEFINITION DOCUMENT**

1 INTRODUCTION

1.1 PURPOSE

The Gary-Chicago-Milwaukee (GCM) Corridor Transportation Information Center (C-TIC) **System Definition Document** describes the C-TIC concept and defines the high level processes and dataflows. The **Requirements Specification** together with the **Interface Control Specification** provide the necessary details to obtain a more in-depth understanding of the system.

1.1.1 Goals of this Document

The C-TIC System Definition Document has the following goals:

- Provide a system overview of the GCM C-TIC for participants in the project and other interested parties.
- To be used as a basis for generating system level requirements and communication interfaces.
- Provide a well documented GCM C-TIC system so that it may serve as a test bed for future ITS technology evolution and system architecture.
- Serve as a prototype for the GCM Gateway.

1.1.2 Intended Audience

The GCM C-TIC System Definition Document is intended for:

- The GCM Architecture, Communication and Information Work Group, in that it provides a system overview of the C-TIC concept.
- Members of the various design groups that have requirements and development responsibility.
- Other interested parties who may be contemplating the design of a similar traffic information clearinghouse system.

1.2 SCOPE

This document provides a conceptual discussion, theory of operation, and system definition of the GCM C-TIC.

This document contains the following sections: Section 1 contains an introduction to this document. Section 2 presents the system overview. Section 3 contains the goals and objectives of the C-TIC. Section 4 discusses the system architecture that is to be implemented. Section 5 presents the operating and design constraints involved in implementing the C-TIC system. Sections 6 and 7 discuss the inputs and outputs involved with connecting the C-TIC to external systems. Section 8 defines the location referencing scheme

that will be used. Section 9 presents the functionality of the user interface. Section 10 presents the proposed C-TIC hardware and operating system. Section 11 discusses the data protocol that is to be used in connecting the C-TIC to external sources of information. Throughout this document are items in *italics* which are to be read as initial estimations and are subject to further investigation and review.

1.3 DEFINITIONS, ACRONYMS, AND ABBREVIATIONS

Document #9936 contains all definitions, acronyms, and abbreviations associated with this project. It also contains information relating to ITS, communications, and other standards.

1.4 RELATED DOCUMENTS

This document is part in a series of documents produced to support the design and development of the GCM C-TIC. Related documents include:

- Document #9932 - Interface Control Specification
- Document #9933 - Requirements Specification
- Document #9935 - Detailed Design Document
- Document #9936 - System Glossary
- Document #9938 - Location Referencing System Document
- Document #9939 - Map Database Analysis Document

2 SYSTEM OVERVIEW

The Gary-Chicago-Milwaukee (GCM) Corridor is one of the corridors selected by the USDOT to receive priority attention under the ISTEA legislation. The corridor is broadly identified by the 16 urbanized counties in the states of Wisconsin, Illinois and Indiana. It includes all major freeways, airports, transit, commuter rail, intercity passenger and freight rail systems, ports and intermodal transfer stations. The GCM corridor extends 130 miles and covers more than 2,500 square miles. It is home to more than ten million people and employs more than four million persons.

The GCM corridor offers the opportunity to support USDOT ITS operational tests and to provide a testbed for long term research and evaluation of ITS. As part of the effort, a twenty year Corridor Program Plan has been developed. This Plan outlines a vision for ITS applications and the creation of a state-of-the-art testbed. It also defines the roles of the participants.

One of the initial focuses of the Corridor Program Plan will be the development of the following systems:

- The Data Pipe communication network
- The Information Clearinghouse computer bulletin board
- The Gateway Transportation Information System

The Data Pipe is an integrated transportation communication network that supports all modes of transportation. The Data Pipe can utilize fiber-optic, microwave, radio, cellular, or any combination of technologies appropriate to the functional and performance requirements of each network element. Facilities can be leased, shared, or owned as appropriate. It is not expected to develop significant new infrastructure but rather to effectively use existing infrastructure and develop new systems as necessary.

As a building block to a state-of-the-art, integrated corridor, the Data Pipe is recognized as a high priority project and one that will provide the framework for development of comprehensive collection, processing and distribution of transportation information.

The Information Clearinghouse is a computer bulletin board system that supports communication and information distribution among corridor transportation agencies. The purpose of the clearinghouse is to provide a common source of information throughout the corridor and a medium to coordinate activities and manage transportation projects.

The Gateway is the central element of this program area. The Gateway is an integrated information system that serves the information needs of operating agencies and travelers within the GCM Corridor. The Gateway collects dynamic and static transportation data from the distributed transportation management systems throughout the corridor. The Gateway compiles and coordinates this data and creates a corridor-wide source of transportation information. The Gateway collects, processes, distributes and presents this information directly to the various operating agencies and to travelers within the GCM Corridor.

The evolution of *ADVANCE* is embodied in the Corridor Transportation Information Center (C-TIC). The Traffic Information Center used in the in-vehicle phase of *ADVANCE* is being expanded to include new

sources of transportation information throughout the three state corridor. The C-TIC will be used as a prototype for both the operational test of the initial GCM data pipe and the Gateway Transportation Information System. The C-TIC will handle the road network database and also real-time travel information from a broader spectrum of interests.

The C-TIC is to be designed to act as a pass-through between various information sources in Illinois, Indiana and Wisconsin. It is not designed to control and/or monitor traffic control devices but rather to facilitate the sharing of information between various agencies, control centers and private firms. This information will include travel times on selected routes, weather information, incident locations, construction information, etc. Minimal processing of the data will occur in the C-TIC.

Congestion and incident information will be provided to all interested agencies, value added resellers and travelers through a map on the Internet. Eventually, transit information will also be available on the Internet.

3 GOALS AND OBJECTIVES

The goals and objectives of the C-TIC are as follows:

- To facilitate the sharing of information between both private firms and public agencies involved in the transportation of goods, materials and people in the GCM Corridor.
- To assist in the improvement of transportation flows in the GCM Corridor.
- To assist in the expansion of multimodal transportation flows.
- To make transportation related information available to both operators and users of the information through local ITS centers.
- To build upon the experience learned with *ADVANCE* and to utilize the Traffic Information Center developed for *ADVANCE* to the maximum extent possible.
- To increase traveler mobility and to reduce travel times and costs by making real time information available to interested parties.
- To improve the level of cooperation between transportation agencies within the corridor.
- To be designed and implemented in a manner that is consistent with an evolutionary deployment within the corridor. This includes the ability to expand to meet the growth of transportation needs within the Corridor and the ability to be modifiable to meet changing operational strategies.
- To be compatible with other ITS implementation efforts within the corridor that are consistent with the Corridor Program Plan.
- To be supportable, maintainable and upgradeable.

4 SYSTEM ARCHITECTURE

The GCM Corridor System is based on a distributed processing system. Control and monitoring of individual traffic control devices remains with the agency responsible for the particular system. For example, changeable message signs on the Borman Expressway will be monitored and controlled by the control center run by INDOT on the Borman. The traffic control centers in each state will typically act as the focal points. Within Wisconsin and Indiana, these control centers will both serve as a focal point within the state to collect data from other agencies and also serve as the connection to the C-TIC. Due to the well developed transportation facilities in the Chicago area, connection of certain transportation facilities in Illinois will either be through the Traffic Systems Center, through the Communications Center, or directly to the C-TIC. Regardless, the C-TIC will function as the "go-between" to connect the traffic control centers in the three states to allow sharing of information. Figure 1 shows a general schematic of the architecture where the C-TIC is the central point of data collection and information dissemination. Details of the data provided by each and information disseminated are shown in Figure 2.

The C-TIC will be designed using the "Onion" approach where the core is the hardware and operating system surrounded by the database and interprocess communications. The next layer contains DBMS report generation applications and other specific applications which connect to the external data sources. The outside layer contains the user interface.

Within the C-TIC, the hardware and software can be categorized into three functional areas: data acquisition, data processing and data dissemination as shown in Figure 3. The data acquisition components acquire data from several sources (e.g., the TSC, MONITOR, SSI weather sensors, etc.) This data may arrive electronically via computers talking to computers; by voice over the telephone; or in a hard copy format via fax or Email. Data that is not transferred electronically will need to be manually entered into the C-TIC. The data may have to be requested or it may be sent automatically. In addition, the data may arrive on a regular basis (e.g., every minute) or randomly (e.g., a 911 call.) Wherever possible, data is to be verified and validated at the source. Suspect data is not to be transmitted to or from the C-TIC.

Before the data can be used, it must undergo data processing. Once the data is sent to the data processing components, it will be stored using an internal C-TIC referencing system. Minimal data fusion will occur as it is intended that the providers of the data will perform data validation prior to transmission. In addition, it is assumed the final users of the information (e.g., the operators of MONITOR, etc.) will make the decision on which data is to be used if conflicting information is received. Data on roadways that are not freeways, expressways, tollways, strategic arterials or highways of national significance will be discarded by the C-TIC if it has not already been filtered at the source prior to transmission.

Following data processing, the data is transferred to the data dissemination components. These components are responsible for providing the data electronically in either textual or graphical format to the users of the system (including the traffic control system operators and other users via a variety of means including kiosks provided by value-added resellers.) The C-TIC will receive information in different formats which will be translated to a standard format. Major data providers will receive information in their own format, but all others will receive information in the C-TIC standard format.

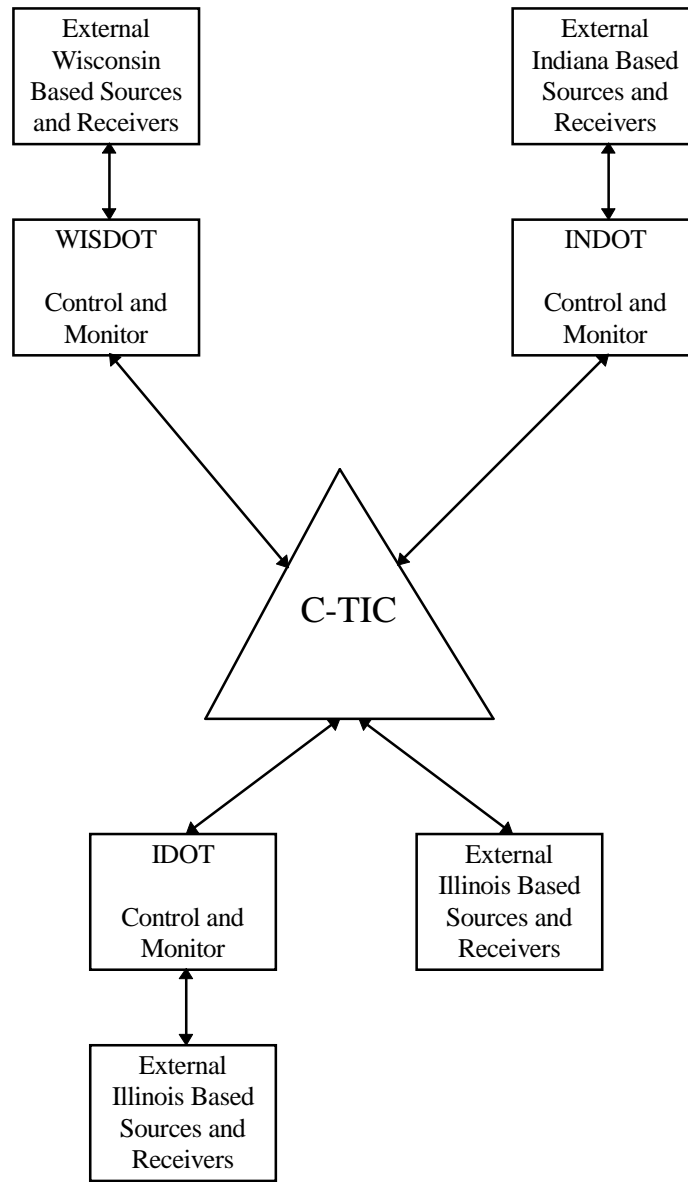

Figure 1. High-Level System Architecture

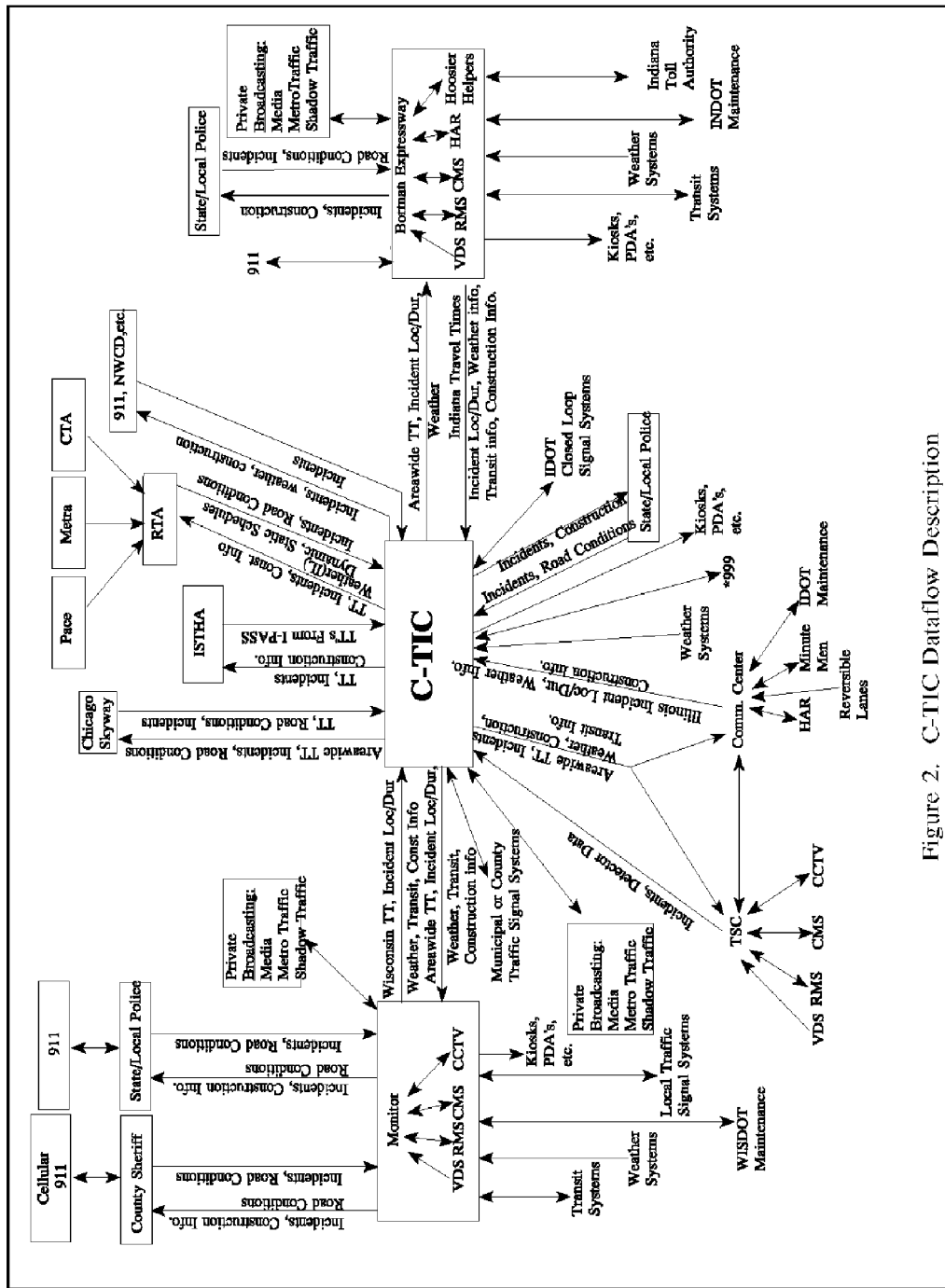

Figure 2. C-TIC Dataflow Description

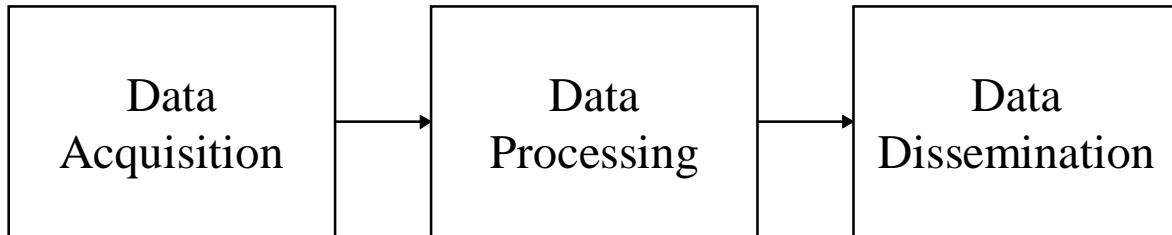

Figure 3. C-TIC High-Level Dataflows

The software will have a variety of functional capabilities. These functional capabilities are to handle specific tasks such as database storage and retrieval, data handling, general process handling, etc., and include the following :

- System Data Acquisition
 - acquisition of data from the various external systems, each of which will be treated as a module
- Data Processing
 - translation of data to the C-TIC standard format
- Data Dissemination
 - transmission of data to the various external data users, each of which will be treated as a module
 - Internet connection
 - *Media interface*
- Graphical User Interface (GUI)
 - status/alarm monitoring
 - data display (e.g., maps, detector data, incident information)
 - system configuration
 - parameter changes
- System Services
 - event scheduler
 - event logger
- Geographical Information Services
 - GIS Translation Service
 - GIS Dynamic Graphics (auto-updated congestion map on Internet)
- Data Management Services
 - system configuration data
 - system log data storage

- GIS map data storage
- database security
- static and real time reporting
- editing support services
- database utilities

- Network Management Services
 - LAN/WAN services
 - electronic mail
 - startup/shutdown
 - power failure recovery

- Security Services
 - auditing services
 - user access control
 - command/level access control
 - system administrative services

5 OPERATING AND DESIGN CONSTRAINTS

The Illinois Department of Transportation will be responsible for the initial operation of the C-TIC. The possibility exists however that the operation may be operated by others (public or private) at a later date.

The C-TIC is to be designed to operate continuously 24 hours per day, 7 days a week in an unattended mode (i.e., all data acquisition, processing and dissemination are designed to be fully automated.) The facility will be staffed initially with an operator present between the hours of 6am and 7pm Central time, Monday through Friday, excluding normal IDOT holidays. The operator's duties are to oversee the operation of the C-TIC, to generate system reports, and to perform system backups of the data.

The C-TIC operator interface is to be designed for PC literate high school/college co-op students with no specific experience in Unix, C, workstations or traffic engineering.

The user interface is to allow for minimal personnel to perform routine data entry and maintenance and for engineers to perform system analyses and administration tasks.

The system shall be portable and scalable.

The C-TIC is to provide minimal processing of data. To the maximum extent possible, information received at the C-TIC is to be pre-processed by the source. For example, rather than receiving raw detector data from MONITOR, travel time data on segments are to be provided.

The C-TIC is not to process the information it receives other than to combine multiple sources of information into an applicable location referencing system. No travel time prediction or incident detection is to be performed. Minimal data fusion is to be performed. If two sources provide conflicting, reliable information, both sets of data are to be forwarded via normal channels to other transportation agencies/users for their review, selection and action.

Data validation and verification is to be performed at the data source to the maximum extent possible. For example, detector data from the TSC is to be checked at the TSC before transmittal to the C-TIC. Suspect data is to be flagged before transmission to the C-TIC.

Information on roadways is to be disseminated only for freeways, expressways, tollways and major arterials that are generally classified as strategic regional arterials or highways of national significance.

The C-TIC design is to operate as a centralized information clearing house by which both private and public agencies can exchange information and operational strategies. The design is to provide for a seamless transportation network while respecting local autonomy.

The design and operation of the C-TIC must fit within the existing organizational infrastructure.

Maximum use of to be made of commercial off the shelf packages where appropriate.

6 EXTERNAL SYSTEMS - INPUT

This section will describe the systems that are expected to serve as data sources to the C-TIC. The C-TIC development will be carried out through the use of three Releases. Each Release will provide for additional data sources and dissemination capabilities. Table 1 describes the features that will be available for each release.

	March 31, 1996	October 13, 1996	December 31, 1996	April 30, 1997	September 30, 1997
Features	Release 1	Release 2	Release 2a	Release 3	Release 4
External Sources and Destinations	TSC Illinois Tollway Manual Fax Capability	SSI (Ill.) NWCD	*999	MONITOR <i>Ind. VMS/HAR</i> Automatic Const. and Maint. Interface SSI (3 states)	<i>Borman</i> Dundee CLSS TSC Expansion <i>Media Interface</i> <i>NWCD (Hoffman</i> <i>Estates and</i> <i>Streamwood)</i> 911 <i>MONITOR (Det.</i> <i>Expansion)</i> <i>Traffic Signal Sys.</i> <i>District 15 CAD</i> <i>Dist. Video Sources</i>
Operator Interface (GUI)	Map Display Process Monitoring Data Monitoring Backup Capability Log Files Standard Reports	Anecdotal Inputs Activity Scheduler Multiple Privilege Levels	Illinois Tollway	Incident Monitor Weather Data (3 states) <i>Ind. VMS/HAR</i> Configurable Rpts. and Graphs	Archiving
Internet	Ill. Cong. (Map) Ill. Travel Times (Map)	Construction and Maintenance data (Ill) Ill. Incident Data (Password Controlled)	Illinois Tollway PIC Server	War Maps (Password Controlled) Weather Data (Password Controlled) Wisc. Cong. (Map) Wisc. Travel Times (Map) Wisc. and *999 Inc. Data (Password Controlled) <i>Ind. VMS/HAR</i>	<i>Ind. Cong. (Map)</i> <i>Ind. Travel Times</i> <i>(Map)</i> <i>Ind. Incident Data</i> <i>(Password</i> <i>Controlled)</i> <i>Firewall</i> Zoomable Maps (Password Controlled)

Table 1 - C-TIC Features vs. Release

6.1 ILLINOIS DATA SOURCES

- Traffic Systems Center - Provide detector data referenced to a detector link number on a one minute basis. Detector data will be sent electronically every one minute and then aggregated over a five minute interval.
- SSI Weather Sensors - Provide information on air temperature, windspeed, pavement temperature, snow/ice conditions, chemical composition of road moisture, and precipitation.
- IDOT Communications Center - Provide information from the following sources:
 - IDOT Maintenance/Construction - Provide construction and maintenance information with location, time, type and estimated impact (if known). Construction and maintenance data on expressways will be provided via fax on a daily basis to the C-TIC. Arterial construction and maintenance information will be provided weekly.
 - State and Local Police - Provide officer based incident location, type (if known), estimated impact (if known), estimated duration (if known), time of detection, clearance time (if known). Provide information on roadway conditions (e.g., hazardous operating conditions-icing, materials on roadway, etc.) Data will be provided *electronically or via fax* on a per occurrence basis to the C-TIC.
 - IDOT - Provide information on HAZMAT monitoring. Data to be provided electronically to the C-TIC on a per incident basis and updated at regular intervals.
- Chicago Transit Authority - Provide information on current train and bus schedules, real time transit information (e.g., which routes are late) and incidents (location, type, time of detection.) Current schedules will be provided on an as needed update basis. Real time information and incident information will be provided *via fax (Internet is being investigated)* to the C-TIC.
- Pace Bus - Provide information on current bus schedules, real time transit information (e.g., which routes are late) and incidents (location, type, time of detection.) Current bus schedules will be provided on an as needed update basis. Real time information and incident information will be provided *via fax (Internet is being investigated)* to the C-TIC.
- Metra Rail - Provide information on current train schedules, real time transit information (e.g., which routes are late) and incidents (location, type, time of detection-including both rail delays and possibly blocked roadways.) Current rail schedules will be provided on an as needed update basis. Real time information and incident information will be provided *via fax (an electronic connection is being investigated)* to the C-TIC.
- *999 - Provide information on incident location, type, and time of detection. Data will be provided to the C-TIC via an electronic transfer. Some filtering of confidential information and incident types

may be required.

- Northwest Central Dispatch/911 Systems - Provide information on incident location, type, time of detection, and clearance time (if known). Data will be provided electronically on a per occurrence basis to the C-TIC. Some filtering of confidential information and incident types may be required.
- Metro Traffic/Shadow Traffic/Other - Provide information on roadway congestion and incidents (location, estimated travel time, etc.) Data will be provided to the C-TIC via fax and phone.
- Municipal or County Traffic Signal Systems - Provide information on incidents/malfunctions including type, location, time of detection, and clearance time. Data will be provided in a variety of ways (electronically, fax, phone) on a per occurrence basis.
- Prototype IDOT Closed Loop Traffic Signal Systems - Provide information on incidents/malfunctions including type, location, time of detection, clearance time. Data to be provided electronically to the C-TIC on a five/fifteen basis for detector data and on a per occurrence basis for incidents and malfunctions. *Travel times will be computed at the C-TIC.*
- ISTHA - Provide travel times on tollways from ETTM referenced to segments. Data to be provided electronically to the C-TIC on a five minute basis. Provide construction and maintenance information with location, time, type and estimated impact (if known.) Fax construction and maintenance reports daily.
- Chicago Skyway - Provide travel times on tollways from ETTM referenced to segments. Data to be provided electronically to the C-TIC on a five minute basis.
- Chicago DOT - Provide information on incidents/malfunctions including type, location, time of detection, and clearance time. *Provide travel time data referenced to detector segment number on a five minute basis.* Data to be provided electronically on a five/fifteen minute basis for detector data and on a per occurrence basis for incidents and malfunctions. Provide construction and maintenance information with location, time, type and estimated impact (if known.)

6.2 INDIANA DATA SOURCES

- Borman Expressway System - Provide travel time data referenced to detector link number on a five minute basis. Provide detector based incident location, type (if known), estimated impact (if known), estimated duration (if known), time of detection and clearance time (if known.) Detector data will be sent electronically every 5 minutes. Incident data will be sent electronically on a per occurrence basis. Act as the focal point for data collection within Indiana and provide information from the following sources:
 - INDOT Maintenance/Construction - Provide construction and maintenance information with location, time, type and estimated impact (if known.) *Provide weather detector information.* Construction and maintenance data will be provided via fax on a daily basis to

the C-TIC. Weather information will be provided electronically on a *15 minute basis* (or directly obtained through a connection to SSI.)

- State and Local Police - Provide officer based incident location, type (if known), estimated impact (if known), estimated duration (if known), time of detection, and clearance time (if known.) Provide information on roadway conditions (e.g., hazardous operating conditions-icing, materials on roadway, etc.) Data will be provided *electronically or via fax* on a per occurrence basis.
- Regional Transit Authorities - Provide information on current train and bus schedules, real time transit information (e.g., which routes are late) and incidents (location, type, time of detection.) Current schedules will be provided on an as needed update basis. Real time information and incident information will initially be provided via fax.
- 911 Systems - Provide information on incident location, type, estimated impact (if known), estimated duration (if known), time of detection and clearance time (if known.) Data will be provided electronically on a per occurrence basis. Some filtering of confidential information and incident types may be required.
- Indiana Toll Authority - Provide travel times on tollways from ETTM referenced to segments. Data to be provided electronically on a five minute basis. (future)
- INDOT - Provide information on HAZMAT monitoring. Data to be provided electronically on a per incident basis and updated at regular intervals.

6.3 WISCONSIN DATA SOURCES

- MONITOR System - Provide volume and occupancy data referenced to detector link numbers every minute. Provide incident location, type (if known), estimated impact (if known), and time of detection every minute while the incident persists. Provide route travel times every minute. Variable message sign data will be sent electronically every minute. MONITOR will act as the focal point for data collection within Wisconsin and provide information from the following sources:
 - WisDOT Maintenance/Construction - Provide construction and maintenance information with location, time, type and estimated impact (if known.) *Provide weather detector information.* Construction and maintenance data will be provided via fax on a daily basis. Weather information will be provided electronically on a *15 minute basis* (or directly obtained through a connection to SSI.)
 - State and Local Police - Provide officer based incident location, type (if known), estimated impact (if known), estimated duration (if known), time of detection, and clearance time (if known.) Provide information on roadway conditions (e.g., hazardous operating conditions-icing, materials on roadway, etc.) Data will be provided via fax on a per occurrence basis.

- Regional Bus Authority - Provide information on current bus schedules, real time transit information (e.g., which routes are late) and incidents (location, type, time of detection.) Current bus schedules will be provided on an as needed update basis. Real time information and incident information will initially be provided via fax.
- 911 Systems - Provide information on incident location, type, estimated impact (if known), estimated duration (if known), time of detection, and clearance time (if known.) Data will be provided electronically on a per occurrence basis. Some filtering of confidential information and incident types may be required.
- Metro Traffic/Shadow Traffic/Other - Provide information on roadway congestion and incidents (location, estimated travel time, etc.) Data will be provided via fax.
- Traffic Signal System - Provide information on incidents/malfunctions including type, location, time of detection, and clearance time. *Provide travel time data referenced to detector segment number on a five minute basis.* Data to be provided electronically on a five/fifteen minute basis for detector data and on a per occurrence basis for incidents and malfunctions.
- WisDOT - Provide information on HAZMAT monitoring. Data to be provided electronically on a per incident basis and updated at regular intervals.

7 EXTERNAL SYSTEMS - OUTPUT

7.1 AREAWIDE DATA

This section describes the systems that are expected to receive areawide data electronically from the C-TIC on expressways, freeways, tollways, strategic arterials and highways of national significance on a five minute update basis.

Data will be provided in a graphical, map based format and in textual displays as appropriate. Typically this data transfer will occur electronically between processors but the ability will also exist to electronically fax this data if necessary. Each center will provide the necessary hardware to enable the proper connections to the C-TIC. Direct data communication feeds will be provided from the C-TIC to the Borman and MONITOR systems if requested. For agencies or other users with intermittent needs, there is a possibility to add a connection at a later date.

The C-TIC will additionally provide information through a GCM Homepage located on the Internet and a *media interface*. All interested parties will be able to access the Internet information but will need to provide their own Internet connections. Some pages which are not for public viewing will be password protected. The media interface connection has yet to be defined.

All data is to be processed and be output for transmission from the C-TIC at the next five minute interval.

7.1.1 Internet Data Receivers

Any person, agency, business, etc. is potentially an Internet data receiver. All that is required to access the information is a connection to the Internet. These Internet data receivers will be able to access travel times and information on major planned maintenance and construction activities including location, type, duration, and time. Information on incidents/malfunions including type, location, time of detection, and *clearance time* will be available from password protected pages. The password protected pages will also contain weather data, VMS data, and detailed detector data. The information is provided in a graphical format with hypertext, mouse-driven selections. Any agency or other users (including value added resellers or operators of Kiosks) with Internet connections will be able to access GCM C-TIC information in this manner. The GCM Homepage is located at:

<http://www.ai.eecs.uic.edu/GCM/GCM.html>

7.1.2 Direct Communication Line Data Receivers

The direct communication line data receivers will be able to access travel times and information on incidents/malfunions including type, location, time of detection, and *clearance time*. Also provided is information on major planned maintenance and construction activities including location, type, duration, and time. The information is provided in *ascii text format* using the location referencing system of the receiving agency and may or may not be directly interfaced to the existing systems depending on the respective agency. The agencies which will be able to access GCM C-TIC information in this manner are:

- Borman Expressway System - INDOT is then responsible for redistributing the information to agencies in Indiana.
- MONITOR System - WisDOT is then responsible for redistributing the information to agencies in Wisconsin.
- Chicago Transit Authority - The CTA will be connected through a fiber optic link at the State of Illinois Center.
- IDOT Traffic Systems Center
- IDOT Communication Center

7.1.3 Other Data Receivers

- Local Phone Number (or perhaps an 800 Number) - Provide computer simulated audio information on travel times and incidents/malfunctions including type, location, time of detection, and clearance time. Provide information on planned maintenance and construction activities including location, type, duration, and time. (Note this may be provided by others within a given state and is to be considered at a future date.)

7.1.4 Media Interface

- Interface not yet defined - Provide travel time, incident, maintenance, and construction data using the standard location referencing system.

7.2 LOCAL DATA

This section describes the systems that are to receive data electronically from the C-TIC on expressways, freeways, tollways, strategic arterials and highways of national significance within geographical areas on a five minute update basis.

This data will be available over the Internet and will utilize the features of the areawide data also located on the Internet. This data will be provided in a graphical, map based format and in textual displays as appropriate. The user will be able to select the specific geographical area through a series of mouse clicks and/or menu selections. By limiting the geographical area, information will only be displayed for the desired area.

8 LOCATION REFERENCING

The C-TIC shall have the responsibility for taking the data it receives and storing it using an internal C-TIC referencing system. It will then have the responsibility for distributing this information to the local traffic management centers or to public agencies in a format that is compatible and useable by that source. This may involve translating coordinate systems, matching road names, matching road addresses, matching segment ID systems, etc. Data sent to private firms or to agencies that do not have a defined format will be in the format used by the C-TIC.

The referencing system to be used within the C-TIC is to be kept as simple as possible utilizing the greatest level of detail that can be accommodated by all contributing data sources. The location referencing system shall accommodate all types of information that may be input into the C-TIC and be capable of supporting unique identifications to reduce the probability of ambiguous locations.

Upon examination, it was determined that there were two potential means for handling Geographic Information System (GIS) conversions from different data sources. First, one could develop custom algorithms to convert from each data source to every other data source and back again. The number of conversion modules grows exponentially with the number of data sources using this technique.

Alternately, one could convert each data source to a common reference system as an intermediate step. To convert to another representation would involve first converting to the common system, then converting to the desired representation. The number of conversion modules grows linearly with the number of data sources in this case.

The first technique has the advantage of being more accurate, but was ruled out due to the large number of conversion modules that might be needed. The first technique also has the disadvantage of transmitting potentially proprietary GIS information to and from the C-TIC. For the C-TIC implementation, it was chosen to develop conversion modules for each major data source to and from the common location referencing system. The common location referencing system that will be used in the C-TIC will represent locations using encoded road names with latitude and longitude to resolve ambiguities.

9 USER INTERFACE

The system shall be provided with both software and hardware to accommodate control and operation of the system, online operator interaction with the software and databases, report generation from the system, and system support activities.

It is expected that there will be a high level of operator interaction during normal weekday working hours. The system shall automatically operate unattended, monitoring subsystems and providing event and status logging, at all other times.

User commands and responses are to be in non-specialist terms that can be readily comprehended by a trained operator. The user interface will ensure that the operator enters a minimum number of keystrokes in order to access a function. The operator will not be required to memorize any commands and on-line help will be available for all functions. The primary input technique will be using the mouse. A secondary input technique will be the use of hot keys (single key entries to speed operator input.)

The operator interface will be user (operator) friendly. Whenever data entry is required, an appropriate prompt will be displayed to guide the operator. Appropriate error messages will be displayed whenever invalid data has been entered.

The system will provide for multi-user capability whereby different users can interact with the system by means of the GUI simultaneously from a minimum of four (4) terminals. All terminals will have full and complete access to the application software and the operating system software dependent only on the access level of the user logged on.

There are two means by which the operator can request actions to be taken by the system: operator request and the activity scheduler. Operator requests shall take place immediately and shall have precedence over the activity scheduler. Operator requests include map displays and data inputs. The activity scheduler shall be used to schedule events by time of day/day of week. Specific operator generated requests include reports, tape backups, etc.

The activity scheduler shall be structured to permit the use of any request at any time in a twenty four hour day, to a one minute resolution. It shall be possible to execute up to five requests in a one minute period. All requests in the activity scheduler shall become effective during the minute in which they are scheduled. It shall be possible to execute 2000 requests in a 24 hour period. It shall be possible to copy the contents of a one day activity schedule to another. The operator shall be able to develop at least 10 individual daily schedules.

All requests which affect system operation (e.g., changing a parameter, stopping a process, etc.) will be adequately protected from operator errors and entered into a log file.

10 C-TIC HARDWARE AND OPERATING SYSTEM

The hardware to be used in the C-TIC is that originally used for the *ADVANCE* TIC as shown in Figure 4. The equipment is housed in a 70" tall standard 19" rack cabinet. The computer is a Sun 670MP (Multiple Processor) SPARC server and has several VME dual wide bus slots for expansion. It currently has 320 Mbytes of Dynamic RAM with error correction circuitry capable of correcting any single bit error. The server is outfitted with four 70 MHz Ross super SPARC processors. There is a total of 13.6 Gbytes of disk storage within the C-TIC, 4.0 Gbytes of disk space on the SPARC station 10 workstation, as well as a 5 Gbyte Exabyte Digital Audio Tape (DAT) backup system. The system console is a Compaq 486/33 PC with a 15 inch color monitor. The main operator/administrator consoles are two Sun SPARC Classic X-terminals and one SPARC station 10 workstation. This provides continuity with one manufacturer. The X-terminals and SPARC station are upgradeable in the future, if necessary to increase performance.

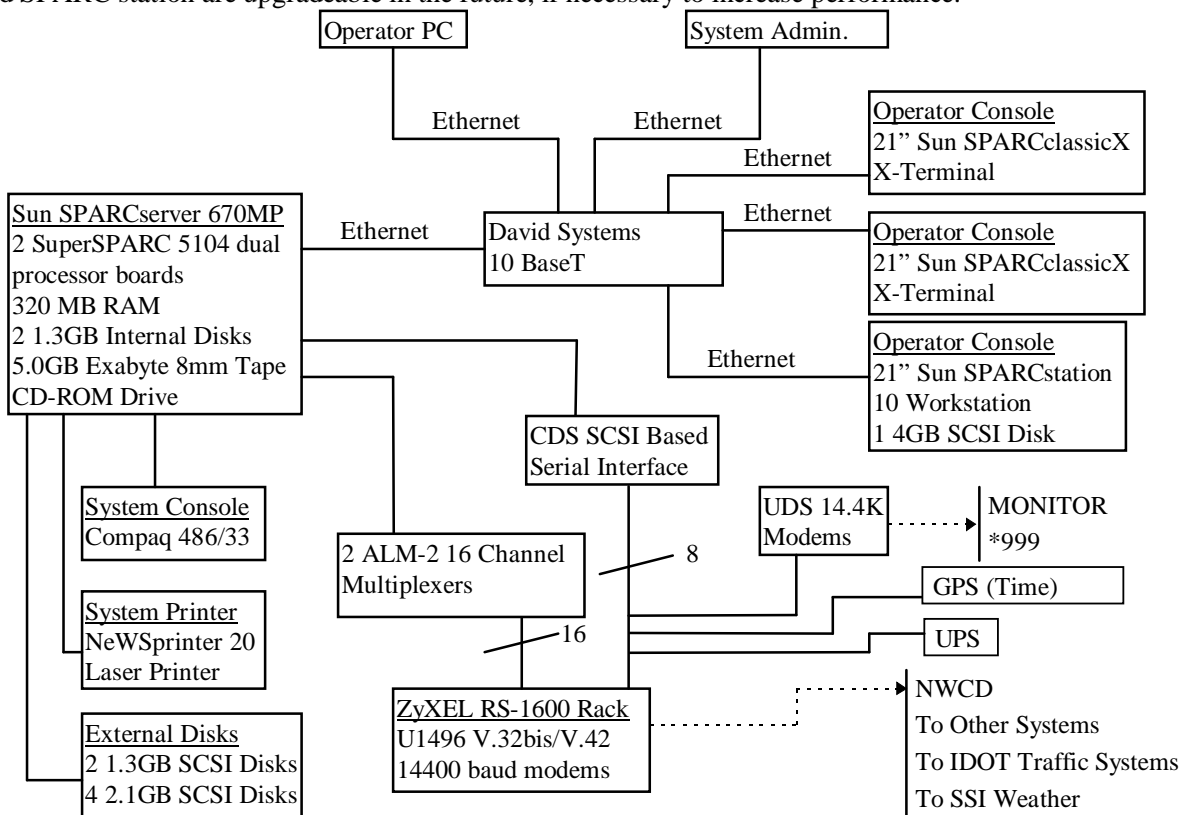

Figure 4. Current *ADVANCE* (C-TIC) Hardware Interconnections

Additional PCs are connected to the network for the operators and for system administration purposes. One PC is located in an adjacent office and the other is located in the C-TIC. Through a communication software package, all C-TIC capability is available on these PCs.

The Sun server is outfitted with two 16 port asynchronous interface cards and a SCSI based serial interface. These adapters provide up to 40 serial I/O ports with which to communicate with external systems/devices. There is a ZyXEL 16 slot rack modem which is used for modem based data. Other modems are also used due to leased line requirements. The main system printer is a Sun Newsprinter20 laser printer (18 pages per minute) which is connected to the server via a special high speed port. The current printer is black and white which reduces the impact and usability of the colors used on the screens and with the Internet maps. For publicity and documentation a color printer is considered as a future upgrade.

The server and the X-terminals are connected via Ethernet using a 10BaseT (twisted pair) wiring system. There is a David Systems concentrator serving a maximum of 12 Ethernet ports. The 10BaseT system was used as it is the native LAN interface for the X-terminals and also because it is relatively easy to configure and wire.

AC power to this equipment is provided via a BEST 5.3 KVA UPS (Uninterruptible Power Supply.) This system provides approximately two hours of protection via internal batteries against power losses and/or interruptions from the commercial power grid. It also conditions the power line.

A projection system which can be used to facilitate operator viewing is under consideration as a future upgrade.

11 DATA PROTOCOL

Interfaces to external systems from the C-TIC end are to be in the public domain. TCP/IP is to be the local area network protocol standard.

Data electronically transmitted to the C-TIC shall conform to that shown in Table 2 which follows. All data is to have a time/date stamp and is to be coded with respect to its source.

Table 2 - C-TIC Input Data Types

ITEM	UNIT	FREQUENCY	ESTIMATED #
<i>DETECTORS (TRAVEL TIMES)</i>	<i>SECONDS (SMOOTHED)</i>	<i>ONCE EVERY ONE MINUTE FOR EACH LINK</i>	<i>1500 TSC XX MONITOR XX BORMAN</i>
<i>DETECTOR LOCATION</i>	<i>LAT.-LONG. OR LINK/ROAD ID</i>	<i>ONCE EVERY ONE MINUTE FOR EACH LINK (WITH TRAVEL TIME)</i>	<i>1500 TSC XX MONITOR XX BORMAN</i>
<i>INCIDENT LOCATION</i>	<i>LAT-LONG. OR LINK/ROAD ID</i>	<i>PER OCCURRENCE</i>	<i>500 CONCURRENT</i>
<i>INCIDENT DURATION (ESTIMATED)</i>	<i>MINUTES</i>	<i>PER OCCURRENCE</i>	<i>500 CONCURRENT (UP TO 43,200 MINUTES EACH)</i>
<i>INCIDENT IMPACT</i>	<i>NO. LANES BLOCKED/IMPACT RATIO</i>	<i>PER OCCURRENCE</i>	<i>500 CONCURRENT</i>
<i>INCIDENT TYPE</i>	<i>ONE OF 20 PREDEFINED TYPES</i>	<i>PER OCCURRENCE</i>	<i>500 CONCURRENT</i>
<i>INCIDENT CLEARANCE TIME</i>	<i>MINUTES</i>	<i>PER OCCURRENCE (IF KNOWN)</i>	<i>500 CONCURRENT</i>
<i>CONSTRUCT. & MAINTEN. ACTIVITIES (TYPE)</i>	<i>ONE OF 20 PREDEFINED TYPES (E.G., ONE LANE CLOSED N/B)</i>	<i>PER OCCURRENCE (RECEIVED DAILY)</i>	<i>1000 CONCURRENT</i>
<i>CONSTRUCT. & MAINTEN. ACTIVITIES</i>	<i>FROM (DATE/HR./MIN.) TO (DATE/HR./MIN.)</i>	<i>PER OCCURRENCE (RECEIVED</i>	<i>1000 CONCURRENT</i>

ITEM	UNIT	FREQUENCY	ESTIMATED #
<i>(DURATION)</i>		<i>DAILY)</i>	
<i>CONSTRUCT. & MAINTEN. ACTIVITIES (LOCATION)</i>	<i>FROM (LAT/LONG OR LINK/ROAD ID) TO (LAT/LONG OR LINK/ROAD ID)</i>	<i>PER OCCURRENCE (RECEIVED DAILY)</i>	<i>1000 CONCURRENT</i>
<i>WEATHER DATA LOCATION</i>	<i>LAT./LONG. OR STATION ID</i>	<i>EVERY 15 MINUTES</i>	<i>500 CONCURRENT</i>
<i>WEATHER DATA TYPE</i>	<i>ONE OF TEN PREDEFINED TYPES</i>	<i>EVERY 15 MINUTES</i>	<i>500 CONCURRENT</i>
<i>WEATHER DATA DURATION</i>	<i>FROM (DATE/HR./MIN.) TO (DATE/HR./MIN.)</i>	<i>EVERY 15 MINUTES</i>	<i>500 CONCURRENT</i>
<i>ETTM DATA (LOCATION)</i>	<i>FROM (LAT/LONG OR LINK ID) TO (LAT/LONG OR LINK/ROAD ID)</i>	<i>PER OCCURRENCE UPDATED EVERY 5 MINUTES</i>	<i>1000 CONCURRENT</i>
<i>ETTM DATA (TRAVEL TIMES)</i>	<i>SECONDS (SMOOTHED)</i>	<i>PER OCCURRENCE UPDATED EVERY 5 MINUTES</i>	<i>1000 CONCURRENT</i>
<i>HAZMAT/WIM DATA (TYPE)</i>	<i>ONE OF TWENTY PREDEFINED TYPES</i>	<i>PER OCCURRENCE UPDATED EVERY 5 MINUTES</i>	<i>100 CONCURRENT</i>
<i>HAZMAT/WIM DATA (LOCATION)</i>	<i>FROM (LAT/LONG OR LINK/ROAD ID) TO (LAT/LONG OR LINK/ROAD ID (ROUTE))</i>	<i>PER OCCURRENCE UPDATED EVERY 5 MINUTES</i>	<i>100 CONCURRENT</i>
<i>TRANSIT DATA (ROUTE)</i>	<i>BUS/TRAIN ROUTE NUMBER</i>	<i>PER OCCURRENCE UPDATED AS AVAILABLE</i>	<i>4000 BUSES/TRAINS</i>
<i>TRANSIT DATA (SCHEDULE)</i>	<i>TIMES (HR./MIN.) AT DESIGNATED STOPS (MAY VARY BY DAY AND WILL BE SCHEDULED AND ACTUAL-REAL</i>	<i>PER OCCURRENCE UPDATED AS AVAILABLE</i>	<i>4000 BUSES/TRAINS</i>

ITEM	UNIT	FREQUENCY	ESTIMATED #
	<i>TIME)</i>		
<i>DETECTOR (VOL. & OCCUP/SPEED)</i>	<i>VEHICLES (VOL.) PERCENT (OCCUP) MPH (SPEED)</i>	<i>EVERY 15 MINUTES FOR EACH LINK (5 MIN. IF AVAILABLE)</i>	<i>500 DETECTORS IN CLOSED LOOP SYSTEMS</i>
<i>DETECTOR LOCATION</i>	<i>LAT.LONG. OR LINK/ROAD ID</i>	<i>WITH EACH VOL, OCCUP, SPEED</i>	<i>500 DETECTORS IN CLOSED LOOP SYSTEMS</i>

Major sources shall receive data in the format they transmit it. Other entities that receive data from the C-TIC but which are not major sources, shall be provided with data in the standard format used within the C-TIC.